

HEPAZONE SW

HEPAZONE SW SERIES BATTERY-POWERED CONTAINMENT CART

The HepaZone SW mobile dust containment cart prevents the spread of dust and hazardous particles in the air during inspection, maintenance and renovation for reasons of abatement, decontamination or infection control.



KEY FEATURES

- ① **EXCLUSIVE** Battery-powered HEPA fan with over 16 hours of autonomy
- ② **EXCLUSIVE** Ratcheting poles with heavy duty steel latches
- ③ Self-extinguishing vinyl with clear vinyl upper cabin
- ④ 25" wide openings at the top to run pipes or conduits into the ceiling
- ⑤ ICRA level I-IV compliant (Infection Control Risk Assessment / Control Cube Method)

HEPANOMAD (MVH-01)

The HepaZone SW has an integrated battery-powered HEPA air scrubber with an airflow capacity of 300 CFM (145 L/s).

The HepaNomad air scrubber is supplied with one HEPA filter and one prefilter, and is powered by two rechargeable 12V 22Ah batteries. A built-in battery level indicator signals when the batteries need to be recharged. It is also equipped with a 6' hospital grade power cord and can run on standard 120V power.

MODEL NUMBER

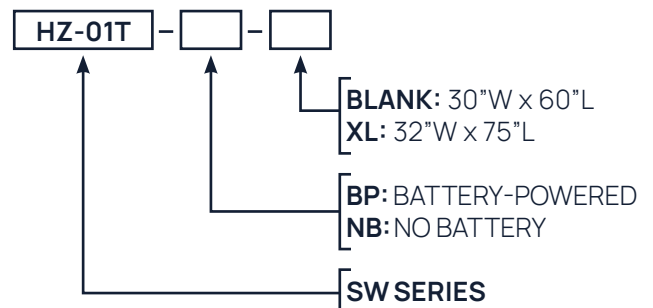

HEPAZONE SW

HEPAZONE SW SERIES BATTERY-POWERED CONTAINMENT CART



OTHER FEATURES

- Full wall access
- Vinyl pouch to display warning signs on exterior of enclosure (16" x 20")
- Floor drain to facilitate cleaning
- Locking swivel casters
- Checkered plate floor

MATERIAL

- Structure: Powder coated steel & aluminum
- Enclosure: Self-extinguishing vinyl
- Windows: Clear vinyl

DIMENSIONS

HEPAZONE SW	HEPAZONE SW-XL
30" (76cm) W	32" (81cm) W
60" (152cm) L	75" (190cm) L
78 to 124" (198 to 315cm) H	78 to 124" (198 to 315cm) H

ACCESSORIES

- **48" EXTENSION KIT**
SKU: HZ-07 (30" W x 60" L)
SKU: HZ-07XL (32" W x 75" L)
- **PROTECTIVE COVER**
SKU: HZ-08 (30" W x 60" L)
SKU: HZ-08XL (32" W x 75" L)
- **TOOL BAG**
SKU: HZ-12
- **TILE ADAPTER**
SKU: HZTA-6060 (60" W x 60" L)
SKU: HZTA-7575 (75" W x 75" L)
- **STICKY MATS SHELF**
SKU: HZ-SR

OPTIONS

- **BATTERY-POWERED HEPA FAN FILTER UNIT**
SKU: HZ-01T - BP - **
- **HEPA FAN FILTER UNIT WITHOUT BATTERY**
SKU: HZ-01T - NB - **

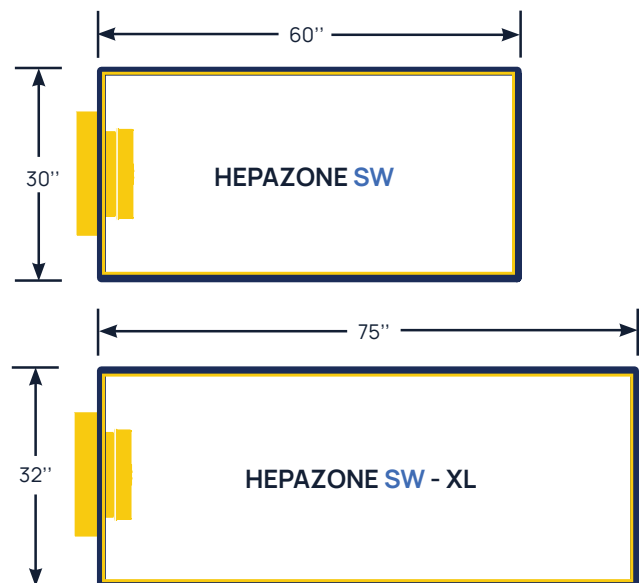

ACCESSORIES

48" EXTENSION KIT

SKU: HZ-07 (30" W x 60" L)
SKU: HZ-07XL (32" W x 75" L)



4' extension kit to reach ceilings over 10'

TOOL BAG

SKU: HZ-12



Tool bag with hooks. Installs on the edge of the top frame

PROTECTIVE COVER

SKU: HZ-08 (30" W x 60" L)
SKU: HZ-08XL (32" W x 75" L)



Protective cover to keep your HepaZone clean during storage

STICKY RACK

SKU: HZ-SR



StickyRack

Underplatform shelf for 24"x36" Sticky Mats

TILE ADAPTER

SKU: HZTA-6060 (60" W x 60" L x 30.4"H)
SKU: HZTA-7575 (75" W x 75" L x 30.4"H)

Tile adapter



Ceiling tile adapter

DIFFERENTIAL PRESSURE GAUGE

SKU: HZ-24



Differential pressure gauge with clip for the HepaZone dust containment carts

COMPARE SERIES



	HEPAZONE NF	HEPAZONE SW	HEPAZONE HD
Standard Dimensions (in) Dimensions Max. (with extension kit) Dimensions Min.	30(L) X 60(W) X 120(H) (168) 30(L) X 60(W) X 78(H)	30(L) X 60(W) X 120(H) (168) 30(L) X 60(W) X 78(H)	30(L) X 60(W) X 130(H) (178) 30(L) X 60(W) X 80(H)
XL Dimensions (in) Dimensions Max. (with extension kit) Dimensions Min.	32(L) X 75(W) X 120(H) (168) 32(L) X 75(W) X 78(H)	32(L) X 75(W) X 120(H) (168) 32(L) X 75(W) X 78(H)	32(L) X 75(W) X 130(H) (178) 32(L) X 75(W) X 80(H)
Enclosure	Vinyl	Vinyl	Aluminum/Vinyl
Air scrubber with 99.99% certified HEPA filter	✗	✓	✓
Over 16 hours of battery autonomy	✗	✓	✓
Universal negative air machine adaptor	✓	✗	✗
5" lockable swivel casters	✓	✓	✓
Full size top opening	✓	✓	✓
Full size wall access	✓	✓	Optional
Flanges to reach wall	✓	✓	Optional
Checkered plate floor	✓	✓	✓
Access panel for long objects	✓	✓	✓
Removable shelves (2)	✗	✗	✓
48" extension kit	Optional	Optional	Optional
Protective cover	Optional	Optional	Optional
Tool bag	Optional	Optional	Optional
Tile adapter (60" x 60")	Optional	Optional	Optional
Underplatform rack for 24" x 36" sticky mats	Optional	Optional	Optional